



wallas[®]

Heaters
and cookers



Wallas Marin | product catalog





Wallas-Marin heaters **Safe | Powerful | Quiet | Reliable**

Story behind the latest NEW Wallas Products

Heating system technology in boats hasn't kept pace with automated home heating systems. We have decided to take this as a challenge and raise Wallas heating technology to a whole new level. We wanted installation to be easier and room thermostat operation more precise.

New low energy Bluetooth beacons let you choose the best locations in the boat to measure temperature. They are detachable and can be moved in different areas of the boat. They also allow you to have multiple measuring points, a very nice feature when you have multiple cabins.

New advanced control panel takes heat control to a new era

We have seen that boats are long term investments of your spare time. Why shouldn't boat accessories be as well? This idea led us to create heaters and control panels with software that can be updated "Over-The-Air". This means that as we keep developing new important features, we can send the features to your heater without taking it out of service. We have started developing several cutting edge programs and features here at Wallas. Some of these features are already released with these new products, but there are more to come.

Wallas heaters are quiet, powerful and reliable, helping you make the most of your boating experience.

We wanted Wallas heaters to be controllable from anywhere you are, just like your home heating system. You can either control the heater with our advanced control panel directly, or choose to control it through a smart phone app locally via Bluetooth. You can also control the heater remotely from your smartphone before you even get to the boat. The new Wallas app shows the current temperature graphs from your boat as well as your battery voltage.

While we have focused on new features and benefits, we have also added quality. System features include service warnings and running hours to help keep your system running longer and more effectively. This feature can predict glow plug failure, low voltage and etc. New low voltage technology ensures that the heater will start even with compromised charging and lower battery levels.

Our intelligent low voltage compensation does the following:

- If the battery voltage is low during start-up, glow time is prolonged to deliver the same amount of heat energy as in normal voltage conditions.
- If the blowers are not able to run at full speed, the heater adjusts itself to a lower power rating while you charge the battery again.

The Revolutionary RPM control

New RPM (Revolutions Per Minute) controlled fans keep accurate blower speed under all conditions. This may seem unimportant, but it is essential to keeping your system running efficiently. Most marine heaters are voltage controlled, but as we know, voltage varies on the boat. So our new systems compensate for voltage and control fan speed by monitoring fan RPM. The ventilation blower can be set to power saving mode so it keeps the hot air output at an exact temperature. This way the system keeps blower speed slower when the outside temperature is very low, when there is no reason to blow colder air to the cabin.





New generation updates with Wallas Spartan and Viking models

New features with Wallas Spartan and Viking units:

- New Advanced Control panel with Bluetooth and Wi-Fi connections.
- Smart phone control
- Multiple options for thermostat sensor. Wired sensor or wireless Bluetooth sensor(s).
- Remote update via Wi-Fi network. Option for updating features and latest software for optimal performance
- Extreme low voltage tolerance.
- Many additional features for special connections. You can control heater safely with digital switch, relay system or traditional main switch or control additional items with your heater control.
- Delivered with wall bracket and floor stand for flexible installation.
- Superior combustion and air flow control by new RPM-controlled fans and flow optimized heat exchanger.

New Wallas Bluetooth Thermostat

- Extremely easy to install and move
- Splash proof
- Works with Bluetooth connection to advanced control panel
- Long battery life
- Heater can have multiple thermostats
- Saves energy
- More accurate temperature control for different locations



Advanced control Panel

- Easy: The new control panel has been designed to be smart, stylish and user friendly.
- Smart device control option: There are many ways to use the control panel over the air. Just set the right temperature for your boat from wherever you want.
- Improved efficiency: Heater has built-in AI-temperature control that anticipates temperature changes, saving energy and making boating life more enjoyable.
- More precision. Wallas advanced control panel makes for fewer temperature variations than traditional heater control systems.
- Great looking design, with easy installation.
- Information storage of heater usage and historical data.
- Wireless Bluetooth thermostat option.
- Intelligent temperature control for cold nights and hot days. Choose automatically between heating and fresh air to optimize comfort.
- Software updates over the air to optimize heater performance now and in the future.
- Pause / Automatic start and stop.
- Pause ventilation, automatically turns the ventilator ON in hot weather.

Advanced control panel lets you control the heater locally or remotely at your convenience.



Wallas Spartan ^{NEW 2019}

- New enhanced low voltage control for startups
- Unit has a new PCB and advanced control panel
- Green Boost burner is more efficient and clean burning
- Very low surface temperatures on chassis and exhaust pipe
- New advanced control panel has Bluetooth / Wi-Fi connection
- RPM controlled fans for optimal performance
- Program updates. Future option for updating programs and controls
- Wallas App control by Wi-Fi and Bluetooth network
- Floor or wall installation options
- Intelligent temperature control for optimizing heating and fresh air
- Option for detachable Bluetooth thermostat beacon(s)



Wallas Spartan

TECHNICAL SPECIFICATIONS

Model	Wallas Spartan
Fuel	Diesel
Power	1400-4500 W
Operating voltage	12 V
Fuel consumption	0,16-0,46 l/h
Electricity consumption	0,7-4,5 A
Heat min	102 m ³ /h
Heat max	227 m ³ /h

COLOR CODES

• the Standard package contains

• Options

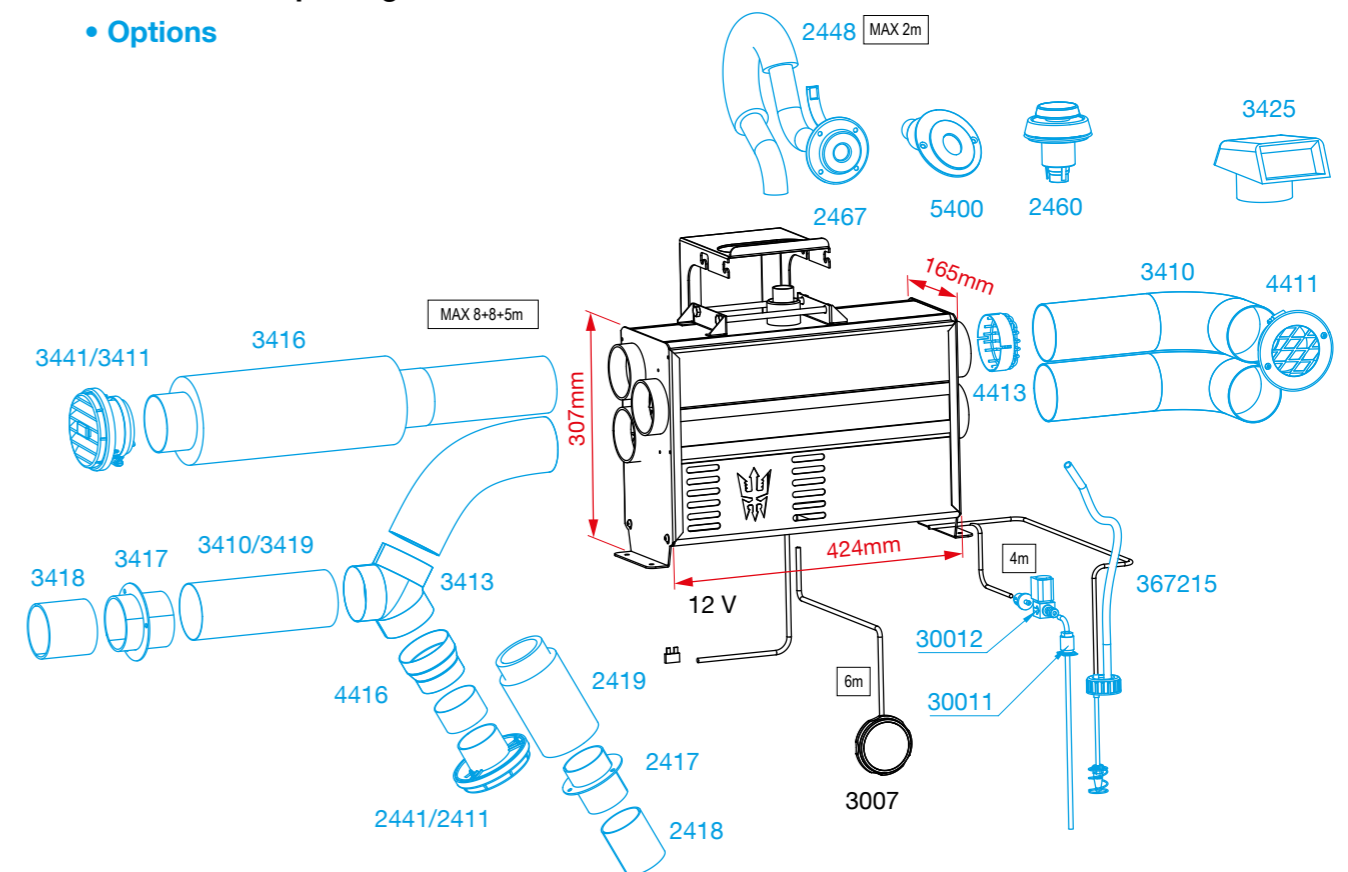



Wallas Viking | Air ^{NEW 2019}

- Unit has a new PCB and advanced control panel
- New enhanced low voltage control for startups
- Can be controlled by Award winning Buster Q and Askeladden C-command screens
- Same size as Dt and GB series heaters
- Green Boost burner is efficient and cleaner burning
- Very low surface temperatures on chassis and exhaust pipe
- New advanced control panel has Bluetooth / Wi-Fi connection
- RPM controlled fans for optimal performance
- Program updates. Future option for updating programs and controls
- Wallas App control by Wi-Fi and Bluetooth network
- Floor or wall installation options
- Intelligent temperature control for optimizing heating and fresh air
- Option for detachable Bluetooth thermostat beacon(s)



Safe | Powerful | Quiet | Reliable

Wallas Viking | Air

TECHNICAL SPECIFICATIONS

Model	Wallas Viking Air
Fuel	Diesel
Power	950-3000 W
Operating voltage	12 V
Fuel consumption	0,1-0,30 l/h
Electricity consumption	0,5-2,0 A (5,4 A with boost)
Heat min	43 m ³ /h
Heat max	121 m ³ /h
Heat boost	182 m ³ /h

COLOR CODES

- the Standard package contains

- Options

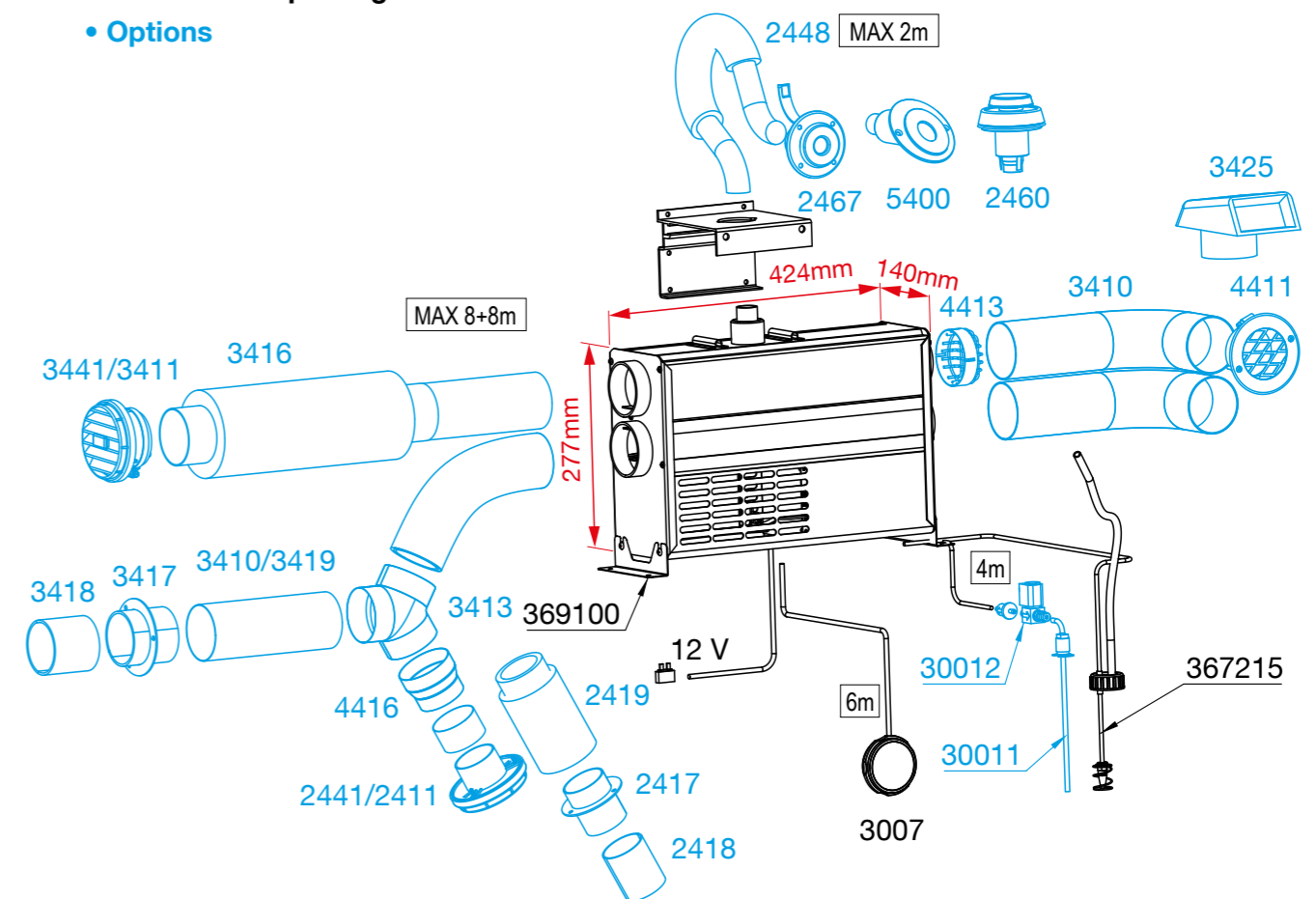



Wallas Viking | Combi ^{NEW 2019}

- Designed for outboard engine boats for heating air and hot water tank (boiler)
- Recommended hot water tanksize: 25 l (6.6 Gal.)
- Unit has a new PCB and advanced control panel
- New enhanced low voltage control for startups
- Can be controlled by Askeladden C-command screen
- Same size as Dt and GB series heaters
- Greenboost burner for more efficient and cleaner burning
- Very low surface temperatures on chassis and exhaust pipe
- New advanced control panel has Bluetooth / Wi-Fi connection
- RPM controlled fans for optimal performance
- Program updates. Future option for updating programs and controls
- Intelligent temperature control for optimizing heating and fresh air
- Option for detachable Bluetooth thermostat beacon
- Floor or wall installation option



Safe | Powerful | Quiet | Reliable

Wallas Viking | Combi

TECHNICAL SPECIFICATIONS

Model	Wallas Viking Combi
Fuel	Diesel
Power	950-2500 W
Air 50-90 % / Water 10-40 %	
Operating voltage	12 V
Fuel consumption	0,1-0,25 l/h
Electricity consumption	0,4-2,6 A
Heat min	33 m³/h
Heat max	73 m³/h

COLOR CODES

- the Standard package contains
- Options

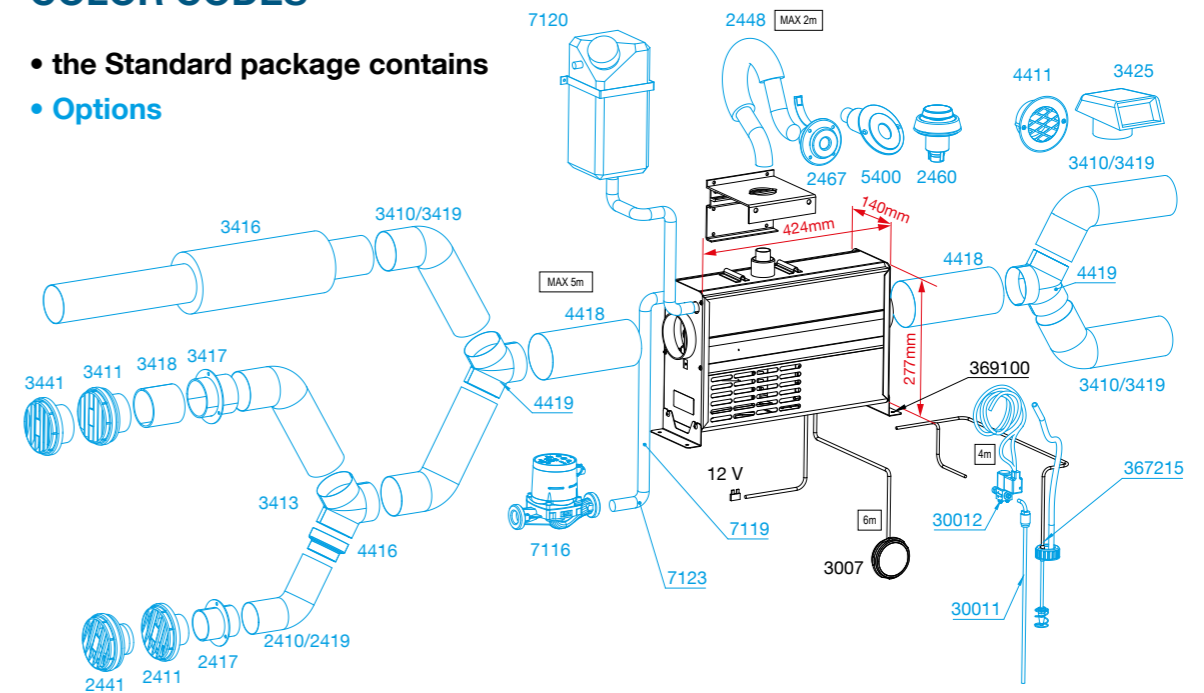

Water heaters ensure even heat distribution in the boat, but also provide domestic **HOT** water.

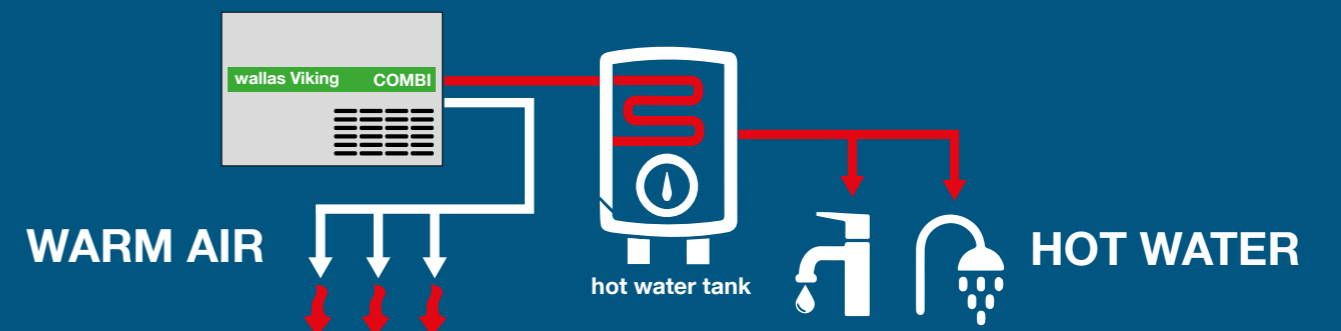



Wallas 22GB

- Powerful 2,2Kw heater for environmentally minded customers!
- Our new 22GB offers increased heating power and greater air volume for boat owners. More heating power means you can heat up your boat faster, saving power and fuel with shorter heating time.
- New, more powerful brushless blower motor gives higher efficiency to the heater and better moisture management, important for wet conditions. Improving on the features of the 22Dt, the new 22GB moves more air, improving ventilation and fresh air flow.
- With its new laminar flow burner and new software, the 22GB is designed to work with today's road and boat diesels (EN590) but also with future renewable (HVO 15940) and blended (B10 EN 16734, B20/B30 EN 16709) bio road diesels. This means the 22GB is ready for fuels being developed for the future. The new burner has ultra-low emissions, including very low CO₂ and NO_x levels.
- Construction features more renewable and recycled materials, while improving durability and reliability, featuring stainless steel, high grade aluminum and other corrosion resistant materials. Wallas-Marin assures you will have the best marine diesel heater for your needs, now and in the future.
- Outside dimensions, controls and connectivity are the same as old 22Dt models. This means upgrading to the new GB heaters is quick and easy!



Safe | Powerful | Quiet | Reliable

Wallas 22GB

TECHNICAL SPECIFICATIONS

Model	Wallas 22GB
Fuel	Diesel
Power	1000-2500 W
Operating voltage	12 V
Fuel consumption	0,1-0,25 l/h
Electricity consumption	0,7-1,2 A
Heat min	51 m ³ /h
Heat max	79 m ³ /h

COLOR CODES

- the Standard package contains
- Options

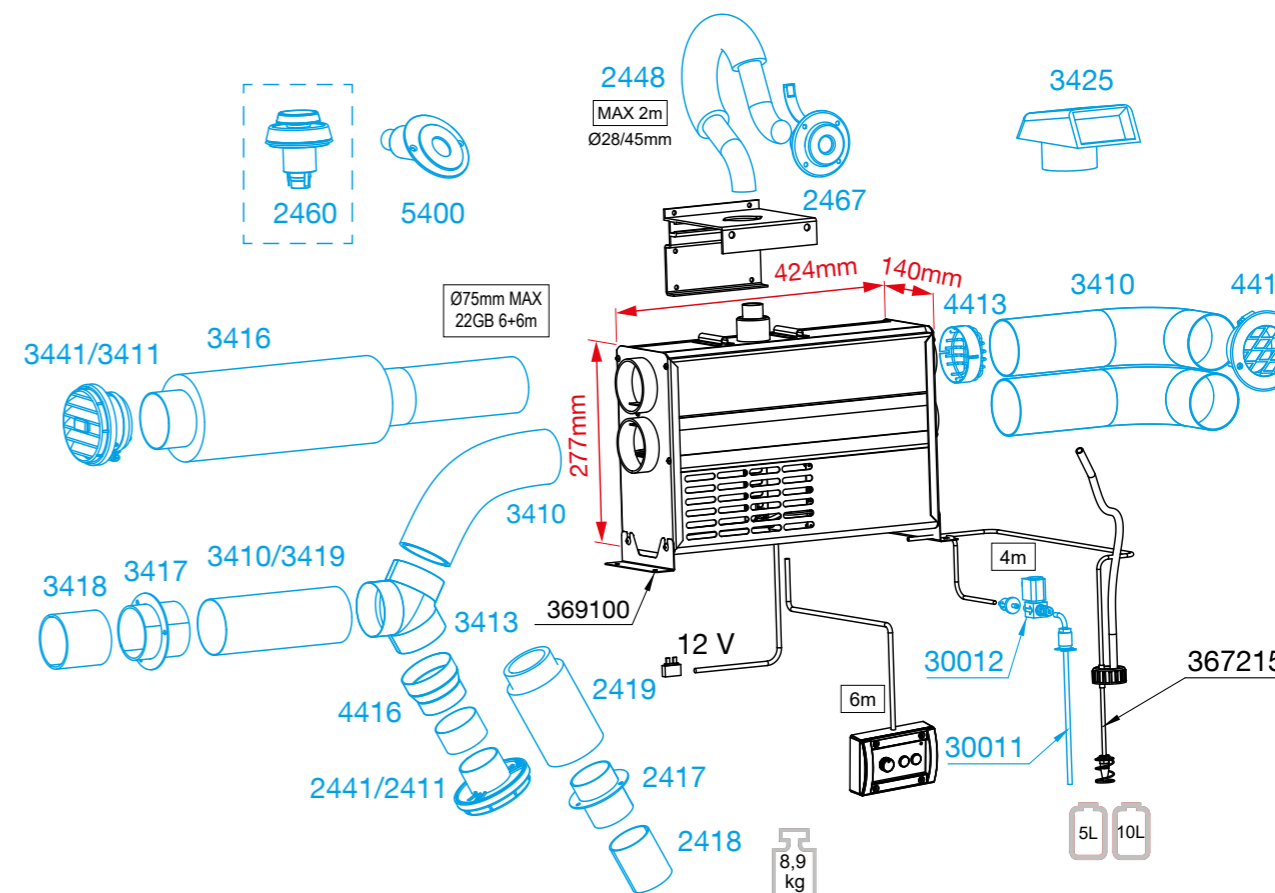



Wallas 30GB

- New, more powerful 3.0Kw heater for environmentally minded customers!
- Our new 30GB offers increased heating power and more air volume for boat owners. More heating power means you can heat up your boat faster, saving power and fuel with shorter heating time.
- New, more powerful brushless blower motors give higher efficiency to the heater and better moisture management, important for wet conditions. Improving on the features of the 30Dt, the new 30GB moves more air, improving ventilation and fresh air flow.
- With its new laminar flow burner and new software, the 30GB is designed to work with today's road and boat diesels (EN590) but also with future renewable (HVO 15940) and blended (B10 EN 16734, B20/B30 EN 16709) bio road diesels. This means the 30GB is ready for fuels being developed for the future. The new burner has ultra-low emissions, including very low CO₂ and NO_x levels.
- Construction features more renewable and recycled materials, while improving durability and reliability, featuring stainless steel, high grade aluminum and other corrosion resistant materials. Wallas-Marin assures you will have the best marine diesel heater for your needs, now and in the future.
- Outside dimensions, controls and connectivity are the same as old 30Dt models. This means upgrading to the new GB heaters is quick and easy!



Safe | Powerful | Quiet | Reliable

Wallas 30GB

TECHNICAL SPECIFICATIONS

Model	Wallas 30GB
Fuel	Diesel
Power	1000-3200 W
Operating voltage	12 V
Fuel consumption	0,1-0,33 l/h
Electricity consumption	1,0-2,0 A
Heat min	61 m ³ /h
Heat max	103 m ³ /h

COLOR CODES

- the Standard package contains
- Options





Wallas 2000t ^{NEW 2019}

- New Paraffin / Kerosene heater
- Will replace 1800t & 2400t units
- Same size as 1800t and 2400t models
- Efficient air control
- Ultra low power consumption
- Very quiet
- 2000 W or 900 W (two stage)
- Updated burning process for Scandinavian conditions
- Cleaner burning and longer service interval



Wallas 2000t

TECHNICAL SPECIFICATIONS

Model	Wallas 2000t
Fuel	Paraffin / Kerosene
Power	900-2000 W
Operating voltage	12 V
Fuel consumption	0,1-0,20 l/h
Electricity consumption	0,4-0,7 A
Heat min	47 m³/h
Heat max	62 m³/h

COLOR CODES

- the Standard package contains
- Options

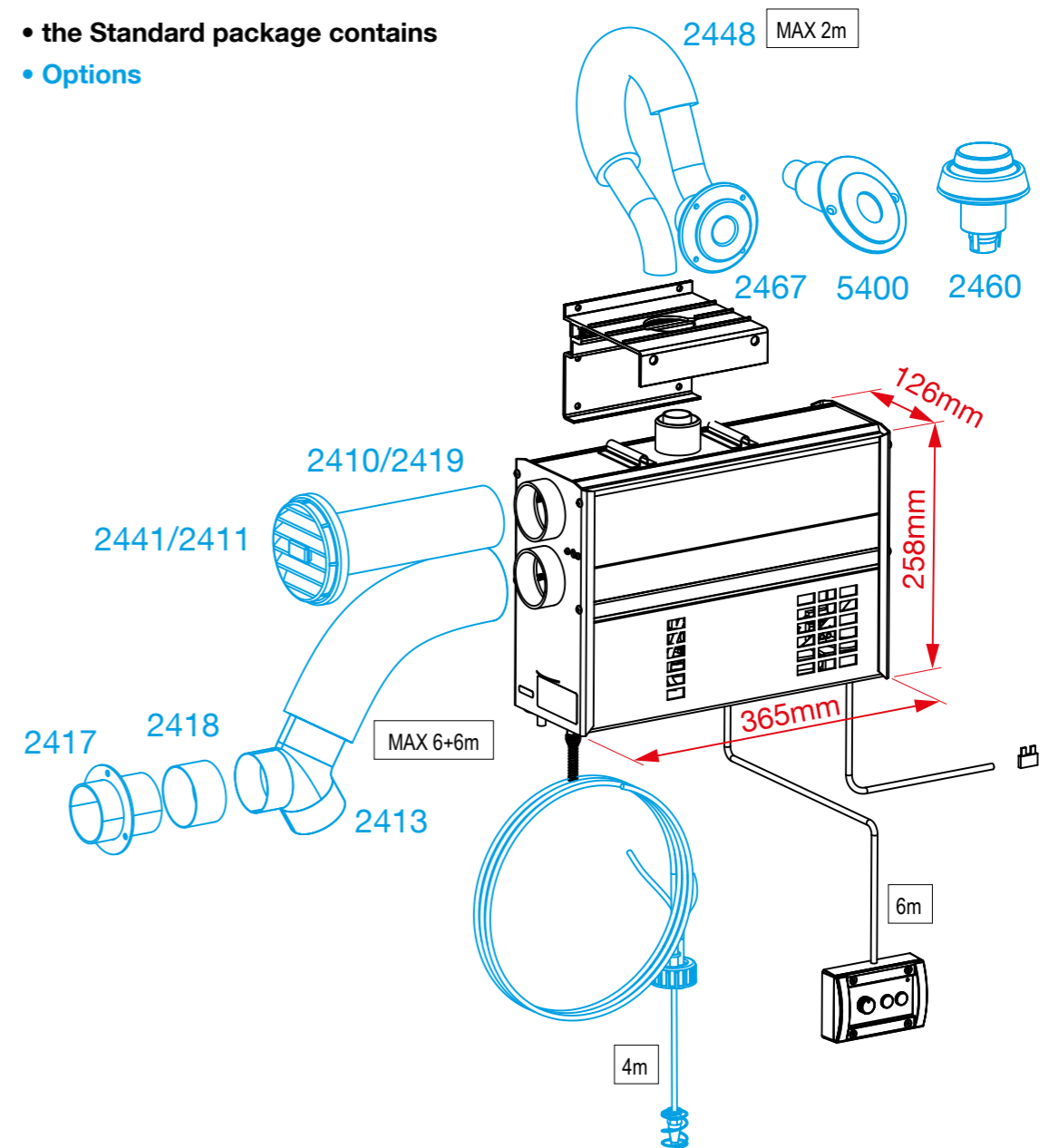



Wallas 1300

- Ideal heater to heat one roomy cabin or cockpit
- Very compact heater with everything you need in one body: fuel pump, control switch, and warm air grill. The heater is thus extremely easy to install.
- Thanks to the laminar burn process the sound level is very low. Furthermore there is no combustion noise, so the boat next to yours can also enjoy the silence of nature.
- 1300 needs just an exhaust outlet, a connection to a battery and some paraffin / kerosene, and that's it, installation is ready!
- Using the heater is even simpler: just switch it on and enjoy the heat



Safe | Powerful | Quiet | Reliable

Wallas 1300

TECHNICAL SPECIFICATIONS

Model	Wallas 1300
Fuel	Paraffin / Kerosene
Power	1200 W 4000 BTU
Operating voltage	12 V
Fuel consumption	0,13 l/h 4,4 oz/hr
Electricity consumption	0,4 A

COLOR CODES

- the Standard package contains

- Options

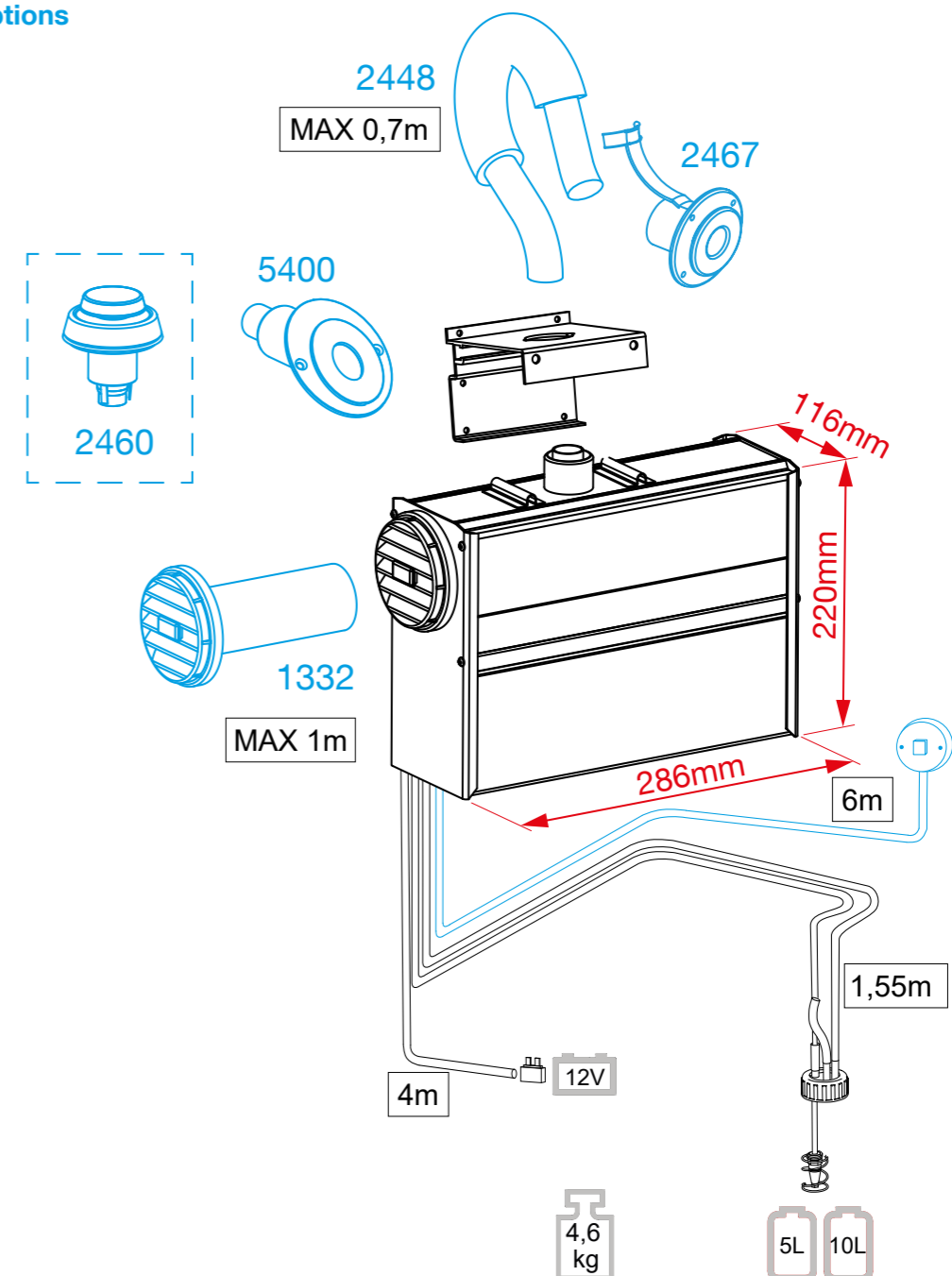



Wallas Black Line

Black line Wallas 85NDt, 85Dt + 270:

- New Black color available for stoves and 270 heater lids.
- State of the art Wallas stove and heater lid.
- Anti-stick color. Easier to clean and works with hot temperatures.
- Heater lid (270) with new, ultra quiet, well controlled brushless blower.
- Cook and heat with single unit.
- Extremely safe, no pressurized gas or exposed flame.
- All combustion gases and water vapor are vented outside for safety and keeping cabin dry.
- Thermostat or manual heating control.
- Handsome design fits modern boat interiors.
- Corrosion free construction materials.



Wallas Black Line 85NDt and 85Dt + 270

TECHNICAL SPECIFICATIONS

Model	Black Line 85NDt, 85Dt
Fuel	Diesel
Power	900-1900 W
Operating voltage	12 V
Fuel consumption	0,09-0,19 l/h
Electricity consumption	0,2-0,35 A
(Heat blower lid 270	0,35-0,5 A)

Available also in stainless steel version:



COLOR CODES

- the Standard package contains
- Options

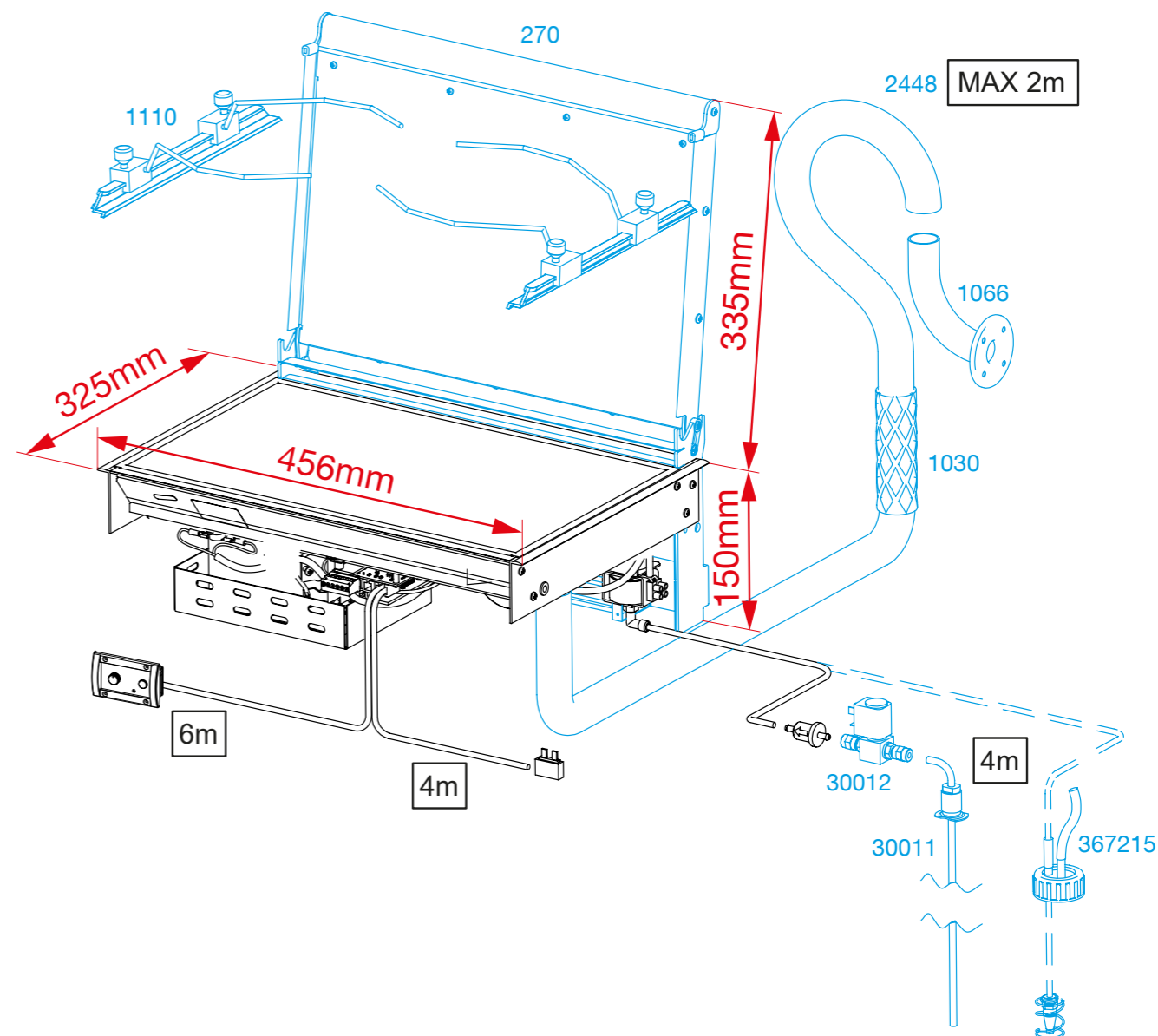



Wallas Black Line

Black line Wallas 800D and 800DSF + 220D:

- New Black color available for stoves and 220D heater lids.
- Anti-stick surface. Easier to clean and works with hot temperatures.
- Heater lid with new program for better temperature control.
- Cook and heat with single unit.
- Extremely safe. No pressurized gas or exposed flame.
- All combustion gases and water vapor are vented outside for safety and keeping cabin dry.
- Thermostat or manual heating control.
- Handsome look fits modern boat interiors.
- Corrosion free construction materials.



Safe | Powerful | Quiet | Reliable

Wallas Black Line 800D and 800DSF + 220D

TECHNICAL SPECIFICATIONS

Model	Black Line 800D, 800DSF
Fuel	Diesel
Power	950-1400 W
Operating voltage	12 V
Fuel consumption	0,10-0,15 l/h
Electricity consumption	0,2-0,4 A
(Heat blower lid 220D	0,4-0,6 A)

Available also in stainless steel version:



COLOR CODES

- the Standard package contains
- Options

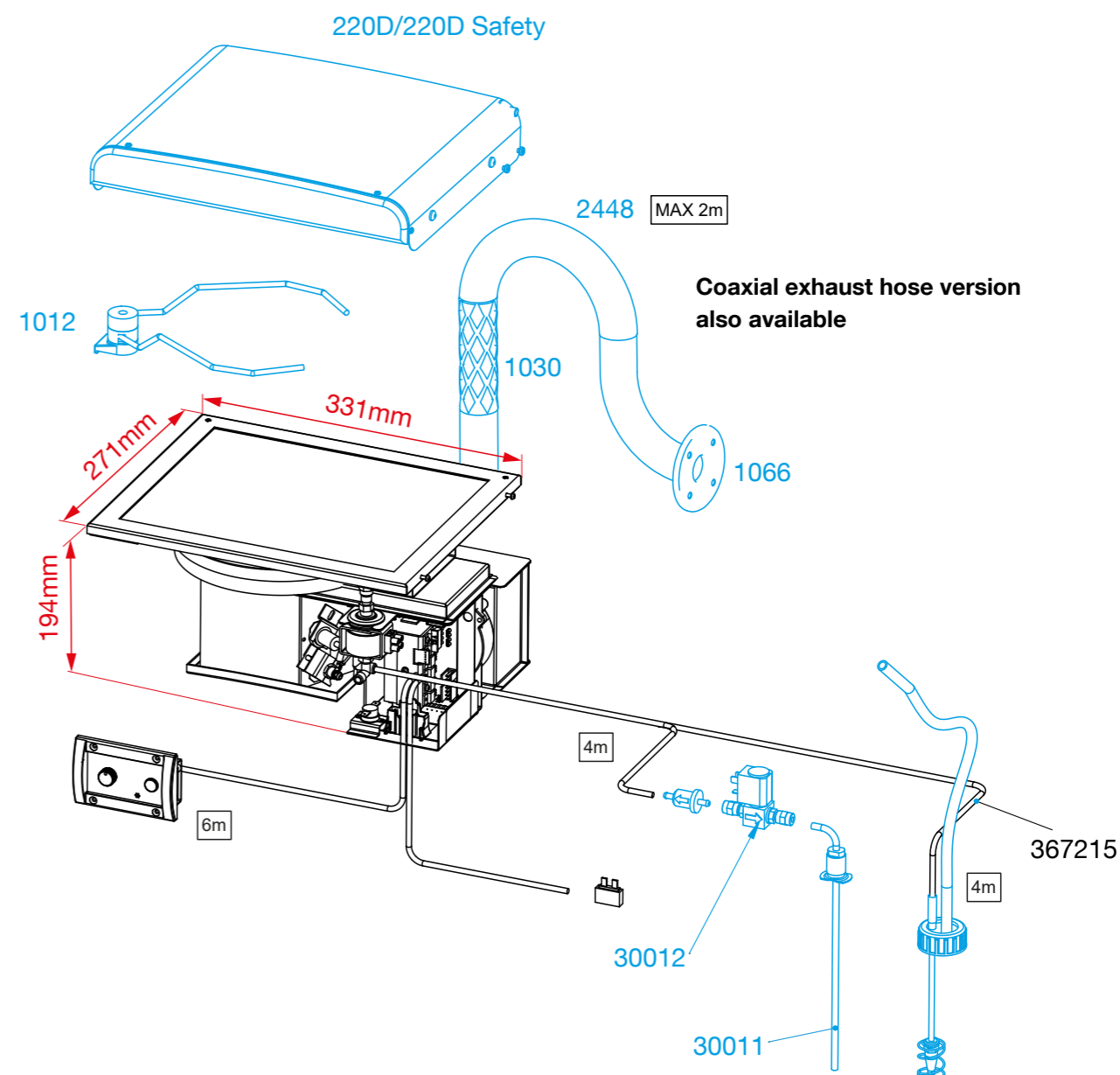



Wallas 88DU

- The Wallas 88 DU is a special flat-design marine diesel stove. A facet-ground ceramic top is all you see when the stove is installed - a state of the art in marine cooking systems.
- Unlike the hazardous propane systems, it uses diesel in its task as a responsive high temperature stove that will give years of service.
- The Wallas diesel stove draws combustion air from inside the cabin and carries exhaust outside the cabin. This feature forces fresh air into the cabin area, drying the vessel interior and reducing the effects of mildew.
- A indication LED in the ceramic glass top warns if the stove is hot.
- Corrosion free construction materials.



Wallas 88DU

TECHNICAL SPECIFICATIONS

Model	Wallas 88DU
Fuel	Diesel
Power	900-1900 W 3000-6500 BTU
Operating voltage	12 V
Fuel consumption	0,09-0,19 l/h 3-6,4 oz/hr
Electricity consumption	0,9 A

COLOR CODES

- the Standard package contains
- Options

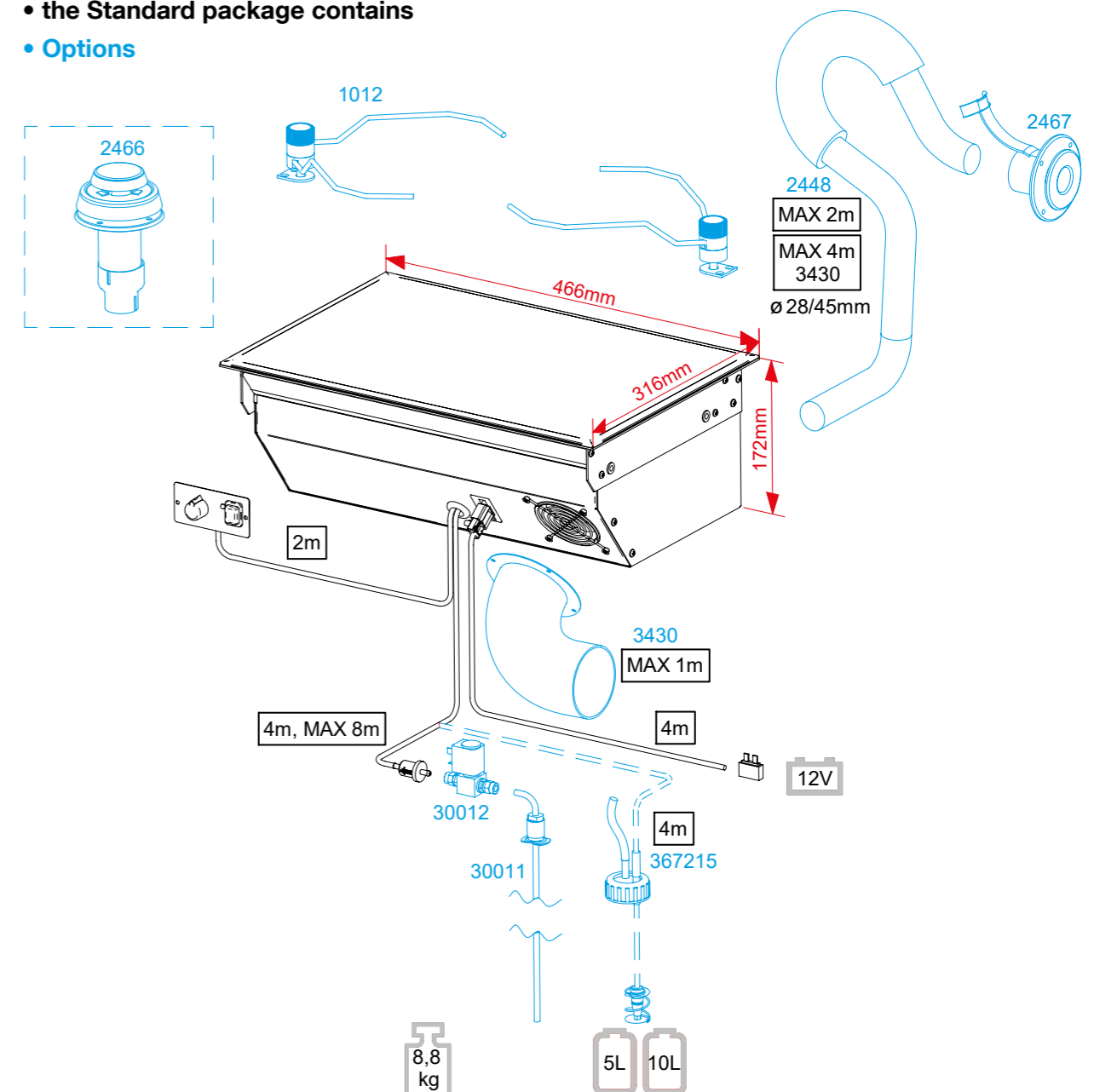



Wallas 85DP

- Wallas 85 DP ceramic stove represents the state of the art in marine cooking systems. Unlike the hazardous propane system, it uses diesel in its task as a responsive high temperature stove that will give years of service.
- The beauty of it is that you can use this stove as a heater as well, when fitted with a Wallas 270 heat blower lid. Imagine – to heat your boat and cook in it with the same unit!
- Unlike other systems, Wallas diesel cooktops draw combustion air from inside the cabin and carry exhaust outside the cabin. This feature forces fresh air to be drawn into the cabin area, drying the vessel interior and reducing the effects of mildew, while enriching the cabin with fresh air.
- Corrosion free construction materials.



Wallas 85DP

TECHNICAL SPECIFICATIONS

Model	Wallas 85DP
Fuel	Diesel
Power	900-1900 W 3000-6500 BTU
Operating voltage	12 V
Fuel consumption	0,09-0,19 l/h 3-6,4 oz/hr
Electricity consumption	0,19 A

COLOR CODES

- the Standard package contains
- Options

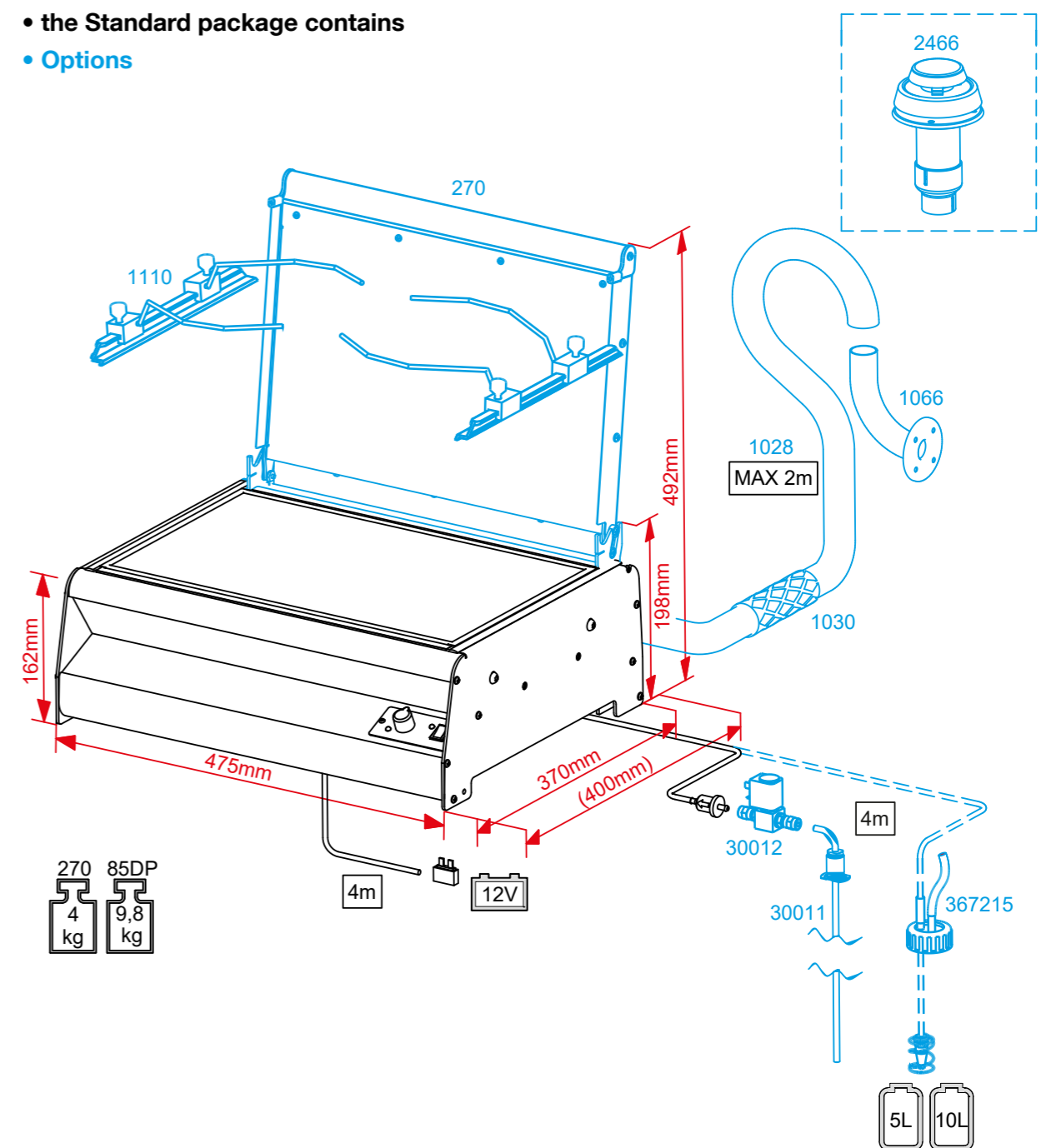



Wallas 86D

- Switch ignition.
- Thermostatic control.
- Safe no-open flame operation.
- All combustion exhaust gases and water vapor is vented outside, keeping cabin dry.
- Clean, soot-free, reliable design minimizes maintenance.
- Diesel fuel can be drawn directly from the main fuel tank or from day tank.
- Super quiet, variable output eliminates off/on system cycling.
- Superb corrosion free stainless steel and aluminium construction.
- Convection oven for fast, accurate cooking times.
- Handy inside oven light.



Safe | Powerful | Quiet | Reliable

Wallas 86D

TECHNICAL SPECIFICATIONS

Model	Wallas 86D
Fuel	Diesel
Power	1000-2500 W 3400-8500 BTU
Operating voltage	12 V
Fuel consumption	0,1-0,25 l/h 3,4-8,5 oz/hr
Electricity consumption	1,6 A

COLOR CODES

- the Standard package contains
- Options

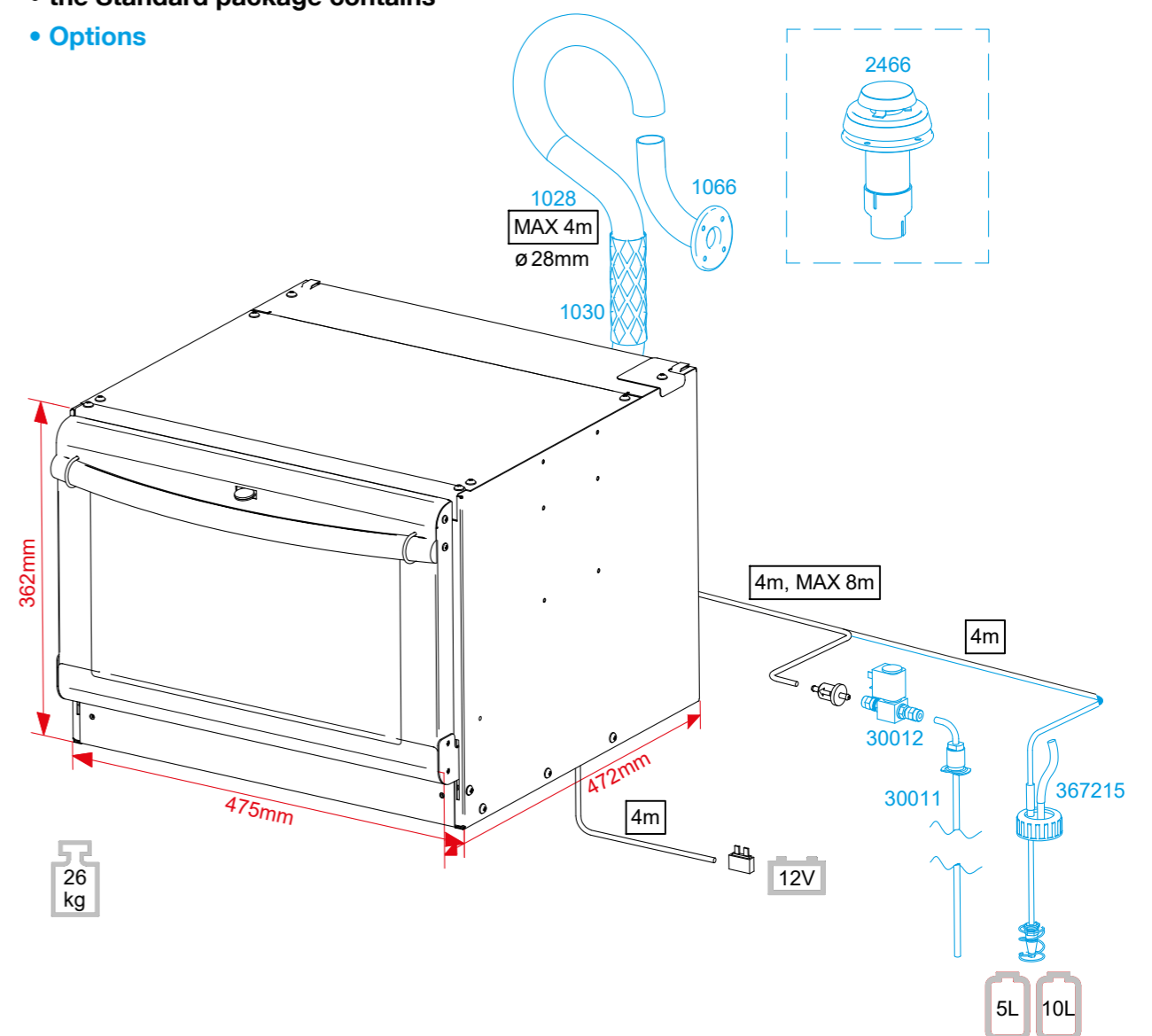



Wallas 87D

- Switch ignition.
- Thermostatic control.
- Safe no-open flame operation.
- All combustion exhaust gases and water vapor is vented outside, keeping cabin dry.
- Clean, soot-free, reliable design minimizes maintenance.
- Diesel fuel can be drawn directly from the main fuel tank or from day tank.
- Super quiet, variable output eliminates off/on system cycling.
- Superb corrosion free stainless steel and aluminium construction.
- Convection oven for fast, accurate cooking times.
- Great oven and stove combination unit.



Safe | Powerful | Quiet | Reliable

Wallas 87D

TECHNICAL SPECIFICATIONS

Model	Wallas 87D
Fuel	Diesel
Power	stove 900-1900 W 3000-6500 BTU oven 1000-2500 W 3400-8500 BTU
Operating voltage	12 V
Fuel consumption	0,09-0,44 l/h 3-15 oz/hr
Electricity consumption	1,06-2,66 A

COLOR CODES

- the Standard package contains
- Options

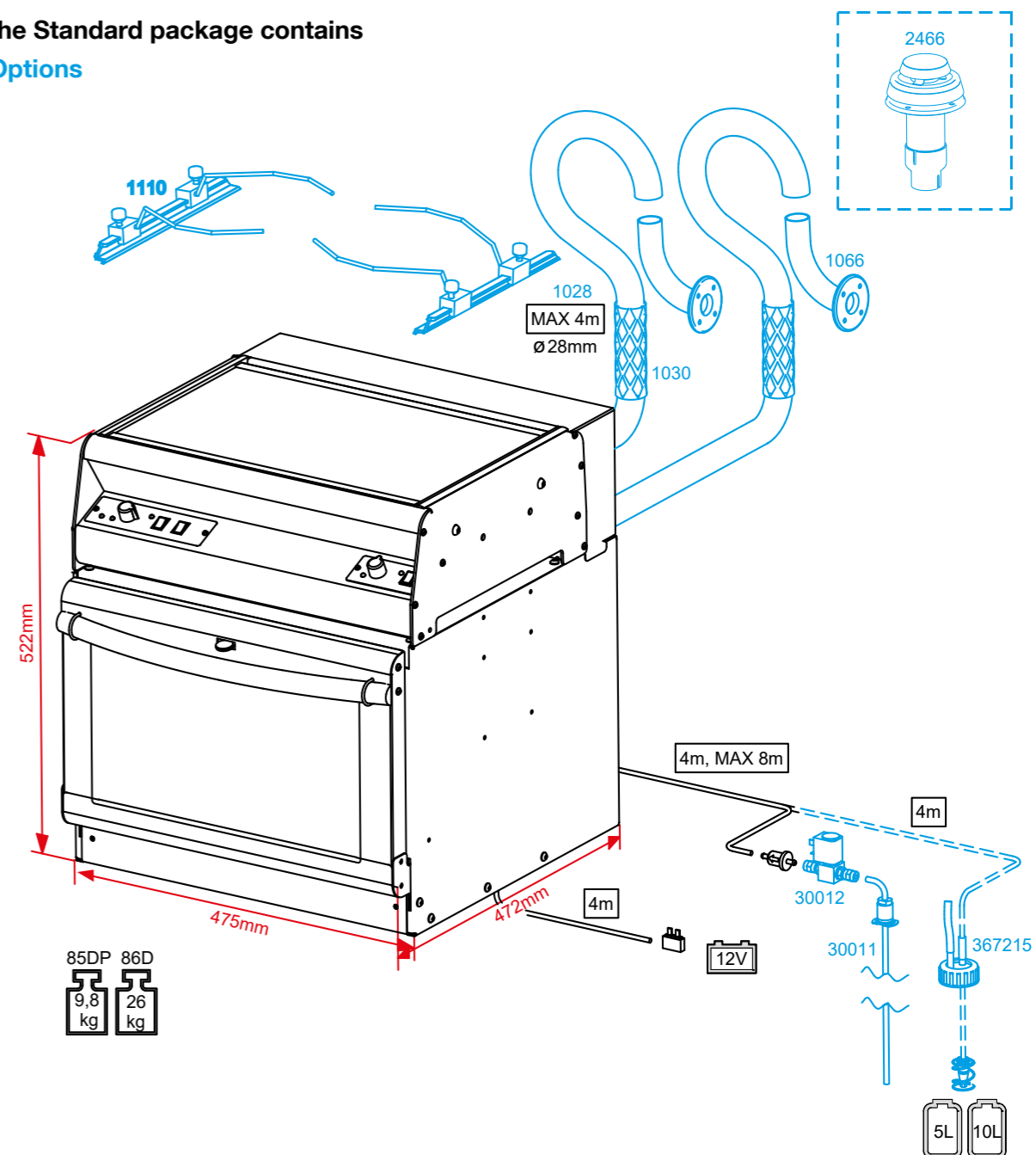



wallas®

Wallas-Marin | wallas.com |  @wallas.fi